

**Submersible drainage pump
with cooling jacket
for clear and drainage water.**

Chromatic C250 WE

Application

Pump for conveying clean or soiled water.

Cellar draining, keeping trenches, shafts and rooms dry. Domestic waste water disposal in cellar rooms (e.g. wash-basins, showers, washing machines). Reduction of surface water. Emergency deployment for flooding. Water extraction from watercourses or reservoirs for irrigation.

A cooling jacket with discharge connector at the top ensures sufficient motor cooling even at low water level (sip operation). The built-in float switch with extremely small construction width allows automatic operation even in particularly narrow shafts. Automatic ventilation with additional air vent screw. Removable strainer allows extraction of residual water down to 5 mm. Automatic purging device can be implemented.

Installation: Stationary or mobile.

Pumped medium: Clear- or drainage water containing solids up to 10 mm particle size. Max. temperature of pumped medium: 35°C, for brief periods up to 60°C.

Operating mode: Continuous operation (S1), at medium temperature 36- 60°C: Intermittent operation (S3 30%).

Design

Submersible pump, consisting of:

Pump: Single-stage centrifugal pump with vertical discharge and integrated non-return valve.

Impeller: Open multi-blade impeller, free passage 10 mm.

Motor: Pressure watertight, medium-immersed motor.

Stainless steel motor housing.

Insulation class B, Protection rating IPX8. Thermal sensor for temperature monitoring in the winding.

Connecting cable: H07RN8-F 3G1.

Shaft/bearing: strongly dimensioned chrome steel motor shaft, lifetime-lubricated roller bearings.

Seal: Shaft seal with triple radial shaft seal and ceramic-coated sealing surface.

Conveying capacity

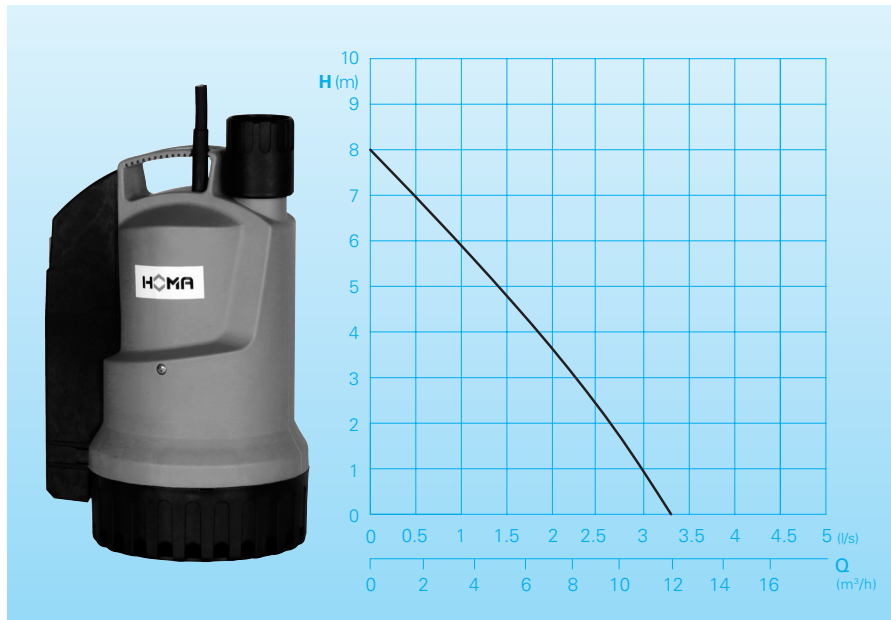

Technical data

Pump type	Motor input		Voltage 50 Hz (V)	Nominal current (A)	Weight (kg)
	P ₁ (kW)	P ₂ (kW)			
C250 WE	0,55	0,26	230/1Ph	2,5	5,3

Rotational speed: 2850 rpm

Discharge: G1 1/4

Materials

Motor housing, motor shaft, screws	Stainless steel
Suction sieve outer housing impeller, pressurized lid	impact-resistant plastic
Elastomers	NBR

Scope of supply

Pump with built-in float switch, twin box G 1¼ inc. integrated non-return valve, washer and hose connection, 10 m of connecting cable and mains plug.

Dimensions and installation example (all dimensions in mm)

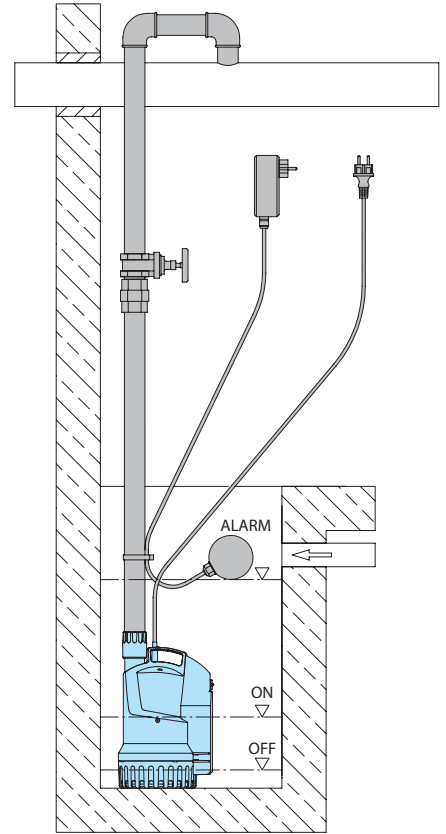
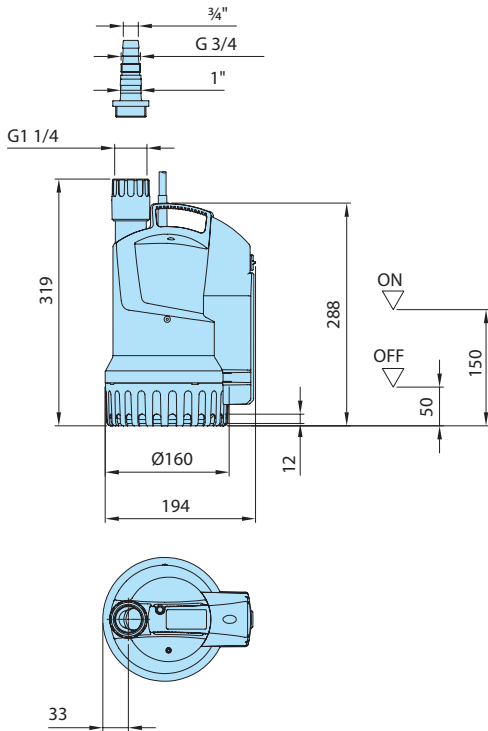

Accessories

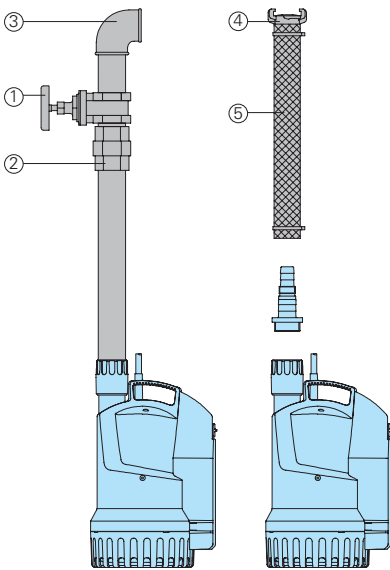

Description	Size	Part no.	Description	Size	Part no.
① Shut-off gate valve, Brass	BSP 1 1/4" F	2216012	○ Fault-current circuit breaker 2-pin, Fi 16/0.03 A		1561160
② Transition screw connection, galvanized	BSP 1 1/4" M/F	2114304	○ Mains-dependent alarm control unit AL3 with connector for 9 V rechargeable battery (see below) for operation independent of mains power supply, with built-in signal transmitter, float switch and 10 m of cable. Main phase connection 230V/1Ph		1586141
③ Connection bend 90°, galvanized	BSP 1 1/4" F BSP 1 1/4" F/AG	2113604 2111405	9 V rechargeable battery for mains-independent alarm		1952215
T-piece for merging the pressure pipe in double pump stations, galvanized	BSP 1 1/4" F	2114301	○ For pump controllers and switchgears for mobile and stationary applications, measuring systems and monitoring devices, see HOMA accessories		
○ Non-return valve, brass (if the integrated non-return valve is omitted)	BSP 1 1/4" F	2211213			
○ Double nipple, galvanized	BSP 1 1/4" M	2009011			
④ Fixed coupling, brass	BSP 1 1/4" M	2005413			
Hose coupling, brass	1 1/4"	2003413			
	1"	2003313			
	3/4"	2003212			
⑤ PVC-hose, per m	1 1/4" Ø 30mm	2621200			
	1" Ø 25 mm	2621000			
	3/4" Ø 19 mm	2620700			
Plastic spiral hose, per m	1 1/4" Ø 32mm	2632030			
	1" Ø 25 mm	2632025			
	3/4" Ø 19 mm	2632019			
Hose clamp	1 1/4"	2302330			
	3/4"-1"	2303252			